

22/25/30/32/35B-9

Electric Counterbalance Trucks

MOVING YOU FURTHER

HYUNDAI HEAVY INDUSTRIES



 **HYUNDAI**

Your satisfaction is **our priority!**

Hyundai introduces a new line of 9-series battery forklift trucks.
The newly designed 4 wheel counterbalance trucks provide every operator
comfortable driving, increased productivity and easy maintenance.



Compact forklift with proven AC technology

Maximum performance

Spacious operator's cab

Fingertip controlled mini levers available (optional)

Weight indicator (optional)

Safety system that prevents over loading (optional)

Battery side loading system available

Curve control system

22/25/30/32/35B-9



High Efficiency & Optimal Performance



More efficient operating control levers

Electronic directional control and secondary horn are mounted to the hydraulic lift lever for quick and precise maneuvering.



Finger tip control levers (Optional)

Fingertip control levers allow more precise control and fatigue-free working. The ergonomically designed armrest can be adjusted up, down, forward and backward for various operator's body type.

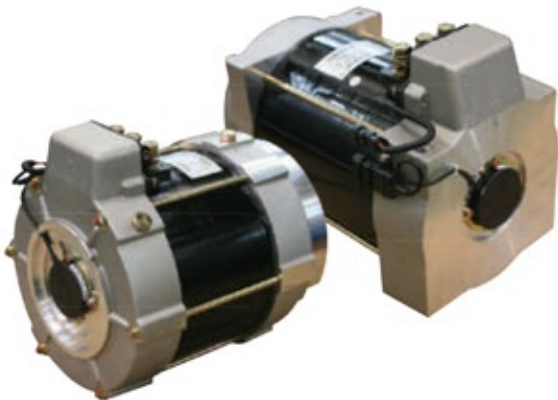

Advanced drive and lift performance with proven durability and low maintenance

The enclosed drive and pump motor with AC technology combine power, high maintenance intervals and excellent durability. The brushless AC motors offer improved efficiency and reduce maintenance cost.

Efficient, smooth running and powerful performance make your work more productive.

22/25/30/32/35B-9



Curve control

Curve Control limits travel speed based on turning radius, reducing speed for a smooth, precise turning operation for the driver.



Driving Speed

Limit the speed



Dual drive system

Using a dual drive system will minimise aisle width and energy consumption. Plus, the drive units and AC motors intergrated in the front axle provide the operator with extremely improved gradient capacity.



Auto fork leveling system (Optional)

In order to improve productivity the auto fork leveling system will automatically stop the tilt movement when the mast is in a straight position.

Max. Gradeability (loaded)

Model	%
22B-9	34
25B-9	31
30B-9	27
32B-9	26
35B-9	23

Max. Travel Speed (unloaded)

Model	Km / h
22B-9	18
25B-9	18
30B-9	18
32B-9	18
35B-9	18

Anti roll back system, travel speed and gradeability

Anti Roll-back system offers protection against the machine rolling back on a ramp in combination with exceptional ramp start capabilities.

Advanced **Safety**



Excellent visibility for safe operation

Optimized lift cylinder arrangement provides operator with wider visibility.
The panoramic mirror expands the driver's view when backing up.



Strong overhead guard

Exceeding CEE and ANSI regulations, the overhead guard offers great protection combined with excellent all-round visibility.

The safely designed driver's space makes your operating more comfortable.

22/25/30/32/35B-9

Fork safety features

When the forks are being lowered, a down-control valve maintains the controlled speed. The down-safety valve prevents forks from dropping down in case of sudden damage of hydraulic line.

OPSS (Operator Presence Sensing System)

When the operator is not in the seat all mast and drive movements are impossible.



Safety lamps & rear reflectors

Halogen headlights and rear LED combination lights offer the driver visibility in all circumstances. Rear reflectors mounted on the counterweight enhance safety for the driver and the application.

Optimised Ergonomics & **Fast and Easy Maintenance**



Spacious operator cabin

The newly designed cabin was conceived for more space, a wider field of view and operator comfort.



Optimized pedal position and floor mat

The position of accelerator and throttle have been optimized through human engineering.



Low entrance height

In order to get in and out of the cabine in an easy and safe way the height of the entrance step is only 400mm high.



Adjustable steering wheel

To achieve a comfortable drive position, the angle of the steering column can easily be adjusted through a lever on the right-hand side of the steering column.



Grammer seat (Option)

An easily adjustable suspension seat, based on a human engineering design, provides greater comfort reducing operator fatigue.

An ideal arrangement of components ensures easy access and convenience for maintenance.

22/25/30/32/35B-9



Easy battery replacement

The battery compartment is equipped with a side battery removal assembly for easy removal and replacement.



Advanced LCD Monitor

This tool is available in 12 different languages. The LCD monitor with 3.5 inch graphic smart display allows the operator to easily and efficiently control the machine.

The monitor provides information about speed & accelerator level, steer angle & travel direction, battery discharge indicator, hour meter & working mode. The optional load indicator displays the load weight in the monitor. The operator can select various performance modes to meet all working conditions.

H (High) mode

N (Normal) mode

E (Economic) mode

Turtle mode (maintain 7 km/h travel speed when lifting)



Brake oil reservoir with level sensor

The enhanced brake oil reservoir, located in the upper left dash, is equipped with an electronic level sensor and easily visible through the monitor.

New 9 Series

Mast Specification (22/25/30B-9)

Mast Type	Maximum Fork Height (mm)	Overall Height (Lowered) (mm)	Free Lift Height (mm)			Tilt Angle Forward / Backward (deg)	Load Capacity without side shift at (500mm LC) (kg)			Load Capacity with side shift at (500mm LC) (kg)			Truck Weight (Unloaded) (kg)			
			With Load Backrest		Without Load Backrest		22B-9	25B-9	30B-9	22B-9	25B-9	30B-9	22B-9	25B-9	30B-9	
			22/25/30B-9	22/25/30B-9	22/25/30B-9											22/25/30B-9
2-Stage Limited free lift	V300	3005	2012	115	115	115	6/10	2200	2500	3000	2200	2500	3000	4028	4293	4557
	* V330	3305	2162	115	115	115	6/10	2200	2500	3000	2200	2500	3000	4047	4312	4578
	V350	3505	2262	115	115	115	6/10	2200	2500	3000	2200	2500	3000	4064	4329	4596
	V370	3705	2412	115	115	115	6/10	2200	2500	3000	2200	2475	3000	4086	4351	4620
	V400	4005	2562	115	115	115	6/10	2200	2500	3000	2200	2425	3000	4108	4373	4644
	V430	4305	2712	115	115	115	6/6	2200	2450	3000	2200	2375	3000	4157	4422	4694
	V450	4505	2862	115	115	115	6/6	2200	2400	3000	2175	2325	2950	4186	4451	4725
	V470	4705	2962	115	115	115	6/6	2200	2360	3000	2125	2285	2875	4201	4466	4741
2-Stage full free lift	VF295	2976	2012	832	1379	1317	6/6	2200	2500	3000	2200	2500	3000	4088	4353	4592
	VF325	3276	2162	982	1529	1467	6/6	2200	2500	3000	2200	2500	2950	4121	4386	4625
	VF345	3476	2262	1082	1629	1567	6/6	2200	2500	3000	2175	2475	2875	4143	4408	4650
3-Stage full free lift	TF370/TS370	3705	1812	632	1122	1117	6/6	2200	2500	3000	2200	2475	3000	4174	4439	4721
	TF400/TS400	4005	1912	732	1222	1217	6/6	2200	2500	3000	2200	2425	3000	4194	4459	4742
	TF430/TS430	4305	2012	832	1322	1317	6/6	2200	2450	3000	2200	2375	2950	4215	4480	4786
	TF450/TS450	4505	2112	932	1422	1417	6/6	2200	2400	3000	2175	2325	2875	4236	4501	4791
	TF470/TS470	4705	2162	982	1472	1467	6/6	2200	2350	2950	2125	2275	2825	4247	4512	4803
	TF500/TS500	5005	2262	1082	1572	1567	6/6	2150	2300	2900	2075	2225	2775	4272	4537	4828
	TF550/TS550	5505	2462	1282	1772	1767	6/6	2100	2200	2800	2025	2125	2675	4311	4576	4871
	TF600/TS600	6005	2662	1482	1972	1967	6/6	2000	2150	2700	1925	2075	2575	4348	4613	4913
4-Stage full free lift	TF650/TS650	6505	2862	1682	2172	2167	3/3	1650	1800	2250	1575	1725	2125	4399	4664	4964
	TF700/TS700	7005	3062	1882	2372	2367	3/3	1200	1400	1850	1125	1325	1725	4432	4697	4997
	QF610	6115	2147	967	1514	1452	3/3	1550	1650	1800	1475	1575	1675	4613	4878	5111
	QF660	6615	2347	1167	1714	1652	3/3	1450	1550	1700	1375	1475	1575	4673	4938	5171
	QF700	7015	2447	1267	1814	1752	3/3	1250	1300	1400	1175	1225	1275	4703	4968	5201
	QF745	7465	2597	1417	1964	1902	3/3	1150	1200	1250	1075	1125	1125	4749	5041	5247
	QF790	7915	2747	1567	2114	2052	3/3	700	750	750	625	675	625	4850	5115	5348

Mast Specification (32/35B-9)

Mast Type	Maximum Fork Height (mm)	Overall Height (Lowered) (mm)		Free Lift Height (mm)				Tilt Angle Forward / Backward (deg)	Load Capacity without side shift at (500mm LC) (kg)		Load Capacity with side shift at (500mm LC) (kg)		Truck Weight (Unloaded) (kg)		
		32B-9	35B-9	With Load Backrest		Without Load Backrest			32B-9	35B-9	32B-9	35B-9	32B-9	35B-9	
				32B-9	35B-9	32B-9	35B-9								
2-Stage Limited free lift	V300	3005	2082	2093	115	115	115	115	6/10	3200	3500	3200	3500	4761	5003
	* V330	3305	2232	2243	115	115	115	115	6/10	3200	3500	3200	3500	4782	5024
	V350	3505	2332	2343	115	115	115	115	6/10	3200	3500	3075	3500	4801	5043
	V370	3705	2482	2493	115	115	115	115	6/10	3190	3500	3065	3500	4825	5067
	V400	4005	2632	2643	115	115	115	115	6/10	3120	3500	2995	3430	4848	5090
	V430	4305	2782	2793	115	115	115	115	6/6	3050	3500	2925	3350	4899	5141
	V450	4505	2932	2943	115	115	115	115	6/6	3000	3450	2875	3300	4931	5173
	V470	4705	3032	3043	115	115	115	115	6/6	2960	3400	2835	3250	4947	5189
2-Stage full free lift	V500	5005	3182	3193	115	115	115	115	6/6	2900	3300	2775	3150	4970	5212
	VF295	2976	2082	2093	913	913	1377	1377	6/6	3200	3500	3200	3500	4815	5057
	VF325	3276	2232	2243	1063	1063	1527	1527	6/6	3200	3500	3200	3430	4838	5080
3-Stage full free lift	VF345	3476	2332	2343	1163	1163	1627	1627	6/6	3200	3500	3075	3350	4864	5106
	TF370/TS370	3705	1882	1893	702	713	1112	1177	6/6	3190	3500	3065	3430	4962	5204
	TF400/TS400	4005	1982	1993	802	813	1212	1277	6/6	3120	3500	2995	3350	4984	5226
	TF430/TS430	4305	2082	2093	902	913	1312	1377	6/6	3060	3450	2935	3300	5009	5251
	TF450/TS450	4505	2182	2193	1002	1013	1412	1477	6/6	3010	3400	2885	3250	5033	5275
	TF470/TS470	4705	2232	2243	1052	1063	1462	1527	6/6	2980	3350	2855	3200	5124	5366
	TF500/TS500	5005	2332	2343	1152	1163	1562	1627	6/6	2920	3300	2795	3150	5072	5314
	TF550/TS550	5505	2532	2543	1352	1363	1762	1827	6/6	2820	3150	2695	3000	5117	5359
4-Stage full free lift	TF600/TS600	6005	2732	2743	1552	1563	1962	2027	6/6	2730	3100	2605	2950	5160	5402
	TF650/TS650	6505	2932	2943	1752	1763	2162	2227	3/3	2300	2600	2175	2450	5211	5453
	TF700/TS700	7005	3132	3143	1952	1963	2362	2427	3/3	1900	2200	1775	2050	5245	5486
	QF610	6115	2147	2158	1017	1017	1459	1459	3/3	1810	2500	1685	2350	5337	5579
	QF660	6615	2347	2358	1217	1217	1659	1659	3/3	1710	2400	1585	2250	5397	5639
	QF700	7015	2447	2458	1317	1317	1759	1759	3/3	1420	2100	1295	1950	5427	5669
	QF745	7465	2597	2608	1467	1467	1909	1909	3/3	890	1950	765	1800	5470	5712
QF790	7915	2747	2758	1617	1617	2059	2059	3/3	500	1450	375	1300	5574	5816	

* TS-Mast: Wide Visible 3-Stage Full Free Lift Mast with 2 Free Lift Cylinders.

* Standard

Load Capacity

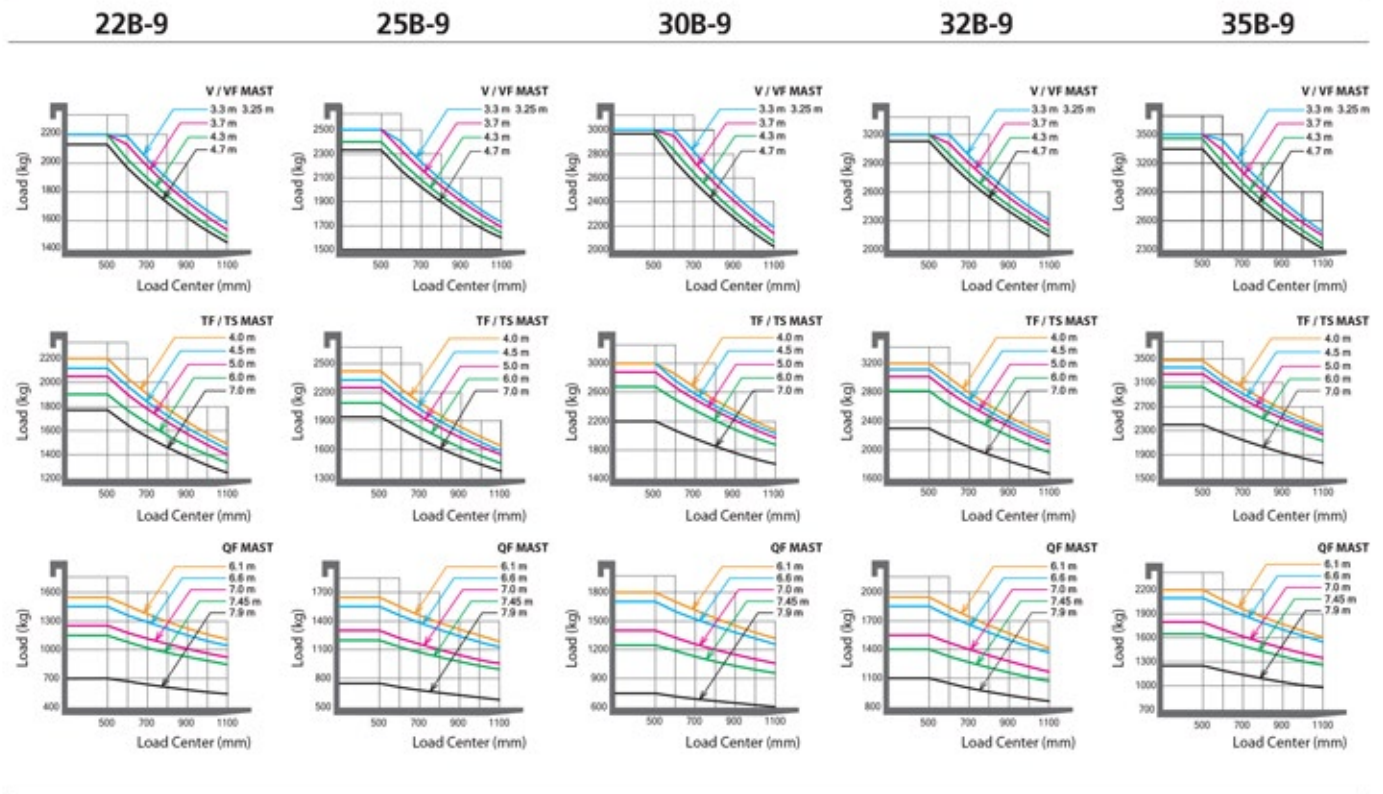

Optional Items

- **Fork (mm)**
 - 22/ 25B-9 : 900, 1000, 1050 (Standard), 1200, 1350, 1500, 1650, 1800
 - 30/32/35B-9 : 900, 1050 (Standard), 1150, 1200, 1650, 1800, 1970, 2120, 2300, 2400
- **Overshoe (mm)**
 - 22/ 25B-9 : 1300, 1500, 1700, 1800
 - 30/32/35B-9 : 1500, 1700, 1800
- **Integral side shift**
- **Tire** : Solid (Standard) / Pneumatic / Non-marking
 - Wide tire [22/25/30/32B-9 : Front tire (23x10-12)]
- **Seat** : Grammer
- **Finger Tip Control**
- **Basic cold storage**
- **M.C.V** : 2-Spool, 3-Spool, 4-Spool (Standard)
- **Auto Fork Leveling** (Standard)
- **Beacon Lamp**
- **Load Indicator**
- **Work Lamp**
- **Cabin**

Dimensions

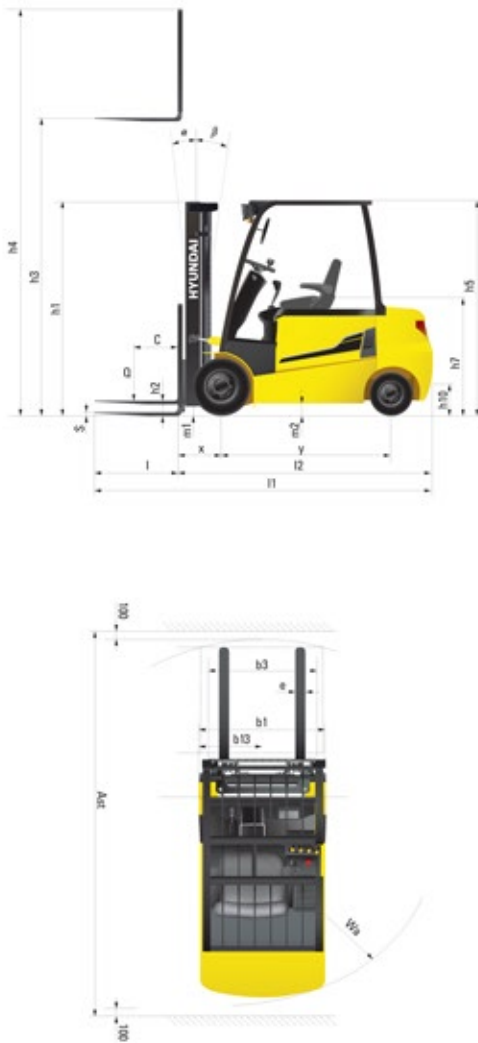

Specifications

Identification		HYUNDAI					
1.1	Manufacturer	HYUNDAI					
1.2	Type	228-9	258-9	308-9	328-9	358-9	
1.3	Drive: Electric, Diesel, LPG Gas	electric	electric	electric	electric	electric	
1.4	Type of operation: hand, pedestrian, standing, seated, order-picker	seated	seated	seated	seated	seated	
1.5	Load capacity (standard)	Q (kg)	2,200	2,500	3,000	3,200	3,500
1.6	Load center distance	c (mm)	500	500	500	500	500
1.8	Load distance, center of drive axle to forks	x (mm)	458	458	458	458	470
1.9	Wheelbase	y (mm)	1,400	1,400	1,600	1,600	1,600
Weights							
2.1	Service weight	kg	4,045	4,310	4,750	4,935	5,190
2.2	Axle loading, loaded front / rear	kg	5,400 / 845	5,930 / 88	6,740 / 1,010	7,080 / 1,055	7,590 / 1,100
2.3	Axle loading, unloaded front / rear	kg	1,695 / 2,350	1,720 / 2,590	1,940 / 2,810	1,965 / 2,970	1,970 / 3,220
Wheels, chassis							
3.1	Tires: solid rubber (V), superelastic (SE), pneumatic (P), polyurethane (PE)		SE, P	SE, P	SE, P	SE, P	SE, P
3.2	Tires size, front (Ø x width)		2309-10	2309-10	2309-10	2309-10	23X10-12
3.3	Tires size, rear (Ø x width)		18X7-8	18X7-8	18X7-8	18X7-8	18X7-8
3.5	Wheels, number front rear (x = driven wheels)		2x/2	2x/2	2x/2	2x/2	2x/2
3.6	Track width, front	b10 (mm)	993	993	993	993	1,005
3.7	Track width, rear	b11 (mm)	980	980	980	980	980
Basic dimensions							
4.1	Mast / fork carriage tilt forward / backward	degrees	6/10	6/10	6/10	6/10	6/10
4.2	Lowered mast height (standard)	h1 (mm)	2,162	2,162	2,162	2,232	2,243
4.3	Free lift	h2 (mm)	115	115	115	115	115
4.4	Lift height (standard)	h3 (mm)	3,300	3,300	3,300	3,300	3,300
4.5	Extended mast height (standard)	h4 (mm)	4,485	4,485	4,485	4,485	4,485
4.7	Overhead load guard (cab) height	h5 (mm)	2,230	2,230	2,230	2,230	2,230
4.8	Seat height / standing height	h7 (mm)	1,180	1,180	1,180	1,180	1,180
4.12	Coupling height	h10 (mm)	325	325	325	325	325
4.19	Overall length	l1 (mm)	3,345	3,345	3,538	3,553	3,640
4.20	Length to face of forks	l2 (mm)	2,295	2,295	2,488	2,503	2,590
4.21	Overall width	b1 (mm)	1,200	1,200	1,200	1,200	1,250
4.22	Fork dimensions (hook type) LxWxT	s / e / t (mm)	1,050 x 100 x 45	1,050 x 100 x 45	1,050 x 122 x 45	1,050 x 122 x 45	1,050 x 122 x 45
4.23	Fork carriage ISO 2328, class / type AB		III/A	III/A	III/A	III/A	III/A
4.24	Fork carriage width	b3 (mm)	1,102	1,102	1,102	1,102	1,102
4.31	Ground clearance, loaded, under mast	m1 (mm)	117	117	117	117	128
4.32	Ground clearance, centre of wheelbase	m2 (mm)	130	130	130	130	130
4.33	Aisle width for pallets 1000 x 1200 crossways (L x W)	Ast (mm)	3,637	3,637	3,829	3,843	3,896
4.34	Aisle width for pallets 800 x 1200 lengthways (W x L)	Ast (mm)	3,803	3,803	4,009	4,023	4,076
4.35	Turning radius	Wa (mm)	1,939	1,939	2,150	2,164	2,205
4.36	Internal turning radius	b13 (mm)	257	257	257	257	257
Performance data							
5.1	Travel speed, loaded / unloaded (48V)	km/h	17 / 18	17 / 18	17 / 18	17 / 18	17 / 18
5.2	Lift speed, loaded / unloaded (48V)	mm/s	420 / 610	410 / 610	340 / 500	330 / 500	300 / 460
5.3	Lowering speed, loaded / unloaded	mm/s	500 / 450	500 / 450	500 / 450	500 / 450	500 / 450
5.6	Drawbar pull, loaded	N	20,310 / 19,910	20,370 / 19,840	20,230 / 19,820	20,170 / 19,790	19,210 / 19,010
5.8	Gradient performance, loaded / unloaded	%	34 / 20	31 / 18	27 / 18	26 / 17	23 / 17
5.10	Service brake		Hydraulic	Hydraulic	Hydraulic	Hydraulic	Hydraulic
E - Motor							
6.1	Drive motor rating S2 60 min (48V)	kW	7.0 x 2	7.0 x 2	7.0 x 2	7.0 x 2	7.0 x 2
6.2	Pump motor rating at S3 - 15 % (48V)	kW	17	17	17	17	17
6.4	Battery voltage, nominal capacity KS (48V)	V/Ah	660	715	740	740	740
6.5	Battery weight	kg	1,090	1,150	1,320	1,320	1,320
	Battery compartment dimensions L / W / H	mm	1,035 / 806 / 540	1,035 / 806 / 540	1,035 / 1,000 / 540	1,035 / 1,000 / 540	1,035 / 1,000 / 540
Other details							
8.1	Type of drive control		AC	AC	AC	AC	AC

- * Standard and optional equipment may vary per country. Contact your Hyundai dealer for more information.
- * The photos may include attachments and optional equipment that are not available in your area.
- * Materials and specifications are subject to change without advance notice.
- * All imperial measurements rounded off to the nearest pound or inch.

PLEASE CONTACT

N.D.L.T. 30 Burkitt Road
Earlstrees Industrial Estate
Corby
Northants
NN17 4DT

TEL: **01536 201755**
Email: **info@ndltcorby.co.uk**

