

35/40/45D-9 50DA-9

Diesel Counterbalance Trucks

MOVING YOU FURTHER

HYUNDAI HEAVY INDUSTRIES



■ Photo may include optional equipment

 **HYUNDAI**

Your satisfaction is **our priority!**

Hyundai introduces a new line of **9-series** diesel forklift trucks.

The newly designed 4 wheel counterbalance trucks provide every operator comfortable driving, increased productivity and easy maintenance.



New Diesel Forklift with Proven Quality and Advanced Technology

- Maximum performance
- Spacious operator's cab
- 5.6 inch LCD color monitor
- Truck inclination warning system
- OPSS System for safe operation
- Easy serviceability
- Max speed limit function
- Password starting system
- Auto fork leveling system (Optional)
- Weight indicator (Optional)
- LED Rear work lamp (Optional)



■ Photo may include optional equipment

High Efficiency & **Optimal Performance**



■ Photo may include optional equipment

CUMMINS QSF3.8 Engine 102 PS / 2,200 rpm 42.3 kgf·m / 1,600 rpm



Powerful Engine

The 4 cylinders turbo-charged engine is built for power, reliability and economy. This engine meets EPA Tier 4 Final and EU stage IV emission regulation.

High Pressure Common Rail Fuel System(HPCR)

Upgraded HPCR System provides excellent start

Ability & Emission Control

- Combustion efficiency enhancement
- Low noise, Low vibration

Selective Catalytic Reduction(SCR)

- Reduces NOx emissions to near-zero level
- NO DPF

Powerful engine and high technology systems provide you with enhanced performance and highest productivity.

35/40/45D-9 50DA-9



Highly Durable Transmission

Powershift transmission of forward 2 stages and reverse 2 stages provides fast travel speed and quiet travel under any heavy load condition, and enhances work efficiency. The clutch protection system prevents excessive use of inching as well as minimizes change-impact.



Boosting Type Brake Valve

The boosting type brake valve is applied for strong braking performance.



Highly Durable Drive Axle

The strengthened drive axle separable from transmission ensures low vibration and easy maintenance. The wet disc type brake is applied for easy operation, smooth response and maintenance free.



Integrated Wheel Rim

The integrated wheel rim provides significantly increased service life.



Fully Hydrostatic Power Steering

The hydraulic steering system always guarantees smooth and flexible steering, preventing over-run and kick-back.



Max. Travel Speed

Model	Km / h
35D-9	26.6
40D-9	25.7
45D-9	25.6
50DA-9	25.6

Max. Gradeability

Model	%
35D-9	40.9 (22.2)
40D-9	36.4 (20.0)
45D-9	33.2 (18.4)
50DA-9	30.6 (17.0)

Faster Travel Speed and Gradeability

The powerful high-output engine provides greater acceleration, better gradeability and faster travel speed on any tough terrain or slope.

Best Convenience & Optimized Ergonomics



■ Photo may include optional equipment

Spacious Operator Cabin

The newly designed cabin provides wide visibility and spacious environment, ensuring all day comfort for the operator.



Optimized Pedal Position

On the 9-series the pedals are mounted to the console to reduce operator fatigue, and noise and dust from the engine compartment.



Adjustable Steering Wheel

To achieve a comfortable drive position, the angle of the steering column can easily be adjusted by a lever on the right-hand side of the steering column.



Grammer Seat (STD)

An attractive and adjustable seat, based on a human engineering design, provides great comfort. And the angle of the armrest can be adjusted to reduce the fatigue of the driver.

- Applied the weight of the driver
- ELR type seat belt standard
- Heater and Head Rest (Option)

The ergonomically designed cabin and the new style LCD color monitor provides full support and comfort to the operator.

35/40/45D-9 50DA-9



Advanced LCD Monitor

The 5.6 inch wide screen LCD color monitor allows the operator to control the machine with ease. The monitor features speed, travel direction, battery discharge indicator and hour meter.

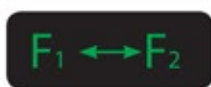

Automatic Gear Box

Automatic transmission is speed controlled:

- During acceleration when the speed reaches 7 km/h second gear is selected .
- When decelerating shift down to first speed is done at 5 km/h.



Truck Inclination Warning System

To improve the productivity and safety, the truck inclination warning system will monitor and indicate forward/backward, right/left degree of the forklift. The alarm alerts the operator when the forklift degree is over the ISO standard.



Load indicator (Option)

The optional load indicator displays the load weight in the monitor. The load sensor reduces the time to check loaded weight and the alarm alerts the driver when overloaded.

Advanced **Safety**



Excellent Visibility for Safe Operation

■ Photo may include optional equipment

Optimized lift cylinder arrangement provides operator with wider visibility.
The panoramic mirror expands the driver's view when backing up.



Strong Overhead Guard

Exceeding CEE and ANSI regulations, the overhead guard offers optimal protection combined with excellent all round visibility.



Low Entrance Height

The low entrance height ensures easy and safe access for the operator.

The safely designed driver's space makes your operating more comfortable.

35/40/45D-9 50DA-9

Fork safety features

When the forks are being lowered, a down-control valve maintains the controlled speed. The down-safety valve prevents forks from dropping down in case of sudden damage of hydraulic line.

OPSS (Operator Presence Sensing System)

When the operator is not in the seat all mast and drive movements are impossible.



Safety Lamps & Rear Reflectors

Halogen headlights and rear LED combination lights offer the driver visibility in all circumstances. Rear reflectors mounted on the counterweight enhance safety for the driver and the application.

Fast and Easy Maintenance



Large Engine Hood

Highly accessible engine compartment assures fast and efficient maintenance.
The enlarged air cleaner (8") extended service time of engine.

■ Photo may include optional equipment



Waterproof and Dustproof Cover

Newly developed Waterproof and Dustproof fuse box and relay box are mounted in one place for ease of maintenance.

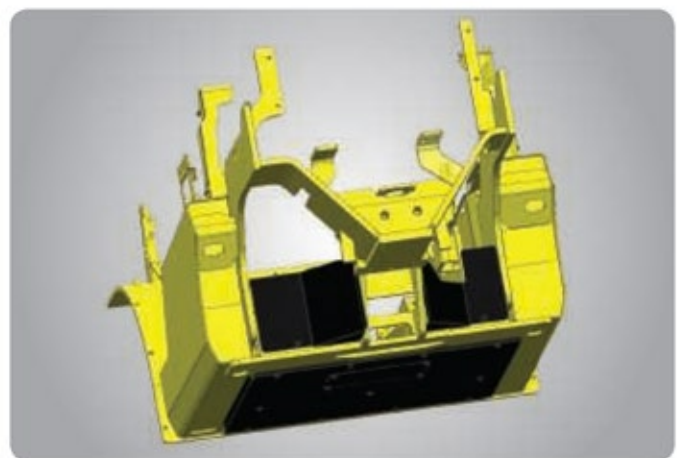

Rear Tire Cover

The rear tire cover is well-suited to prevent clogging of the radiator from foreign substances.

An ideal arrangement of components ensures easy access and convenience for maintenance.

35/40/45D-9 50DA-9



Rear View Camera
(Optional)



Emergency
Switch

■ Photo may include optional equipment

Maintenance Management			
Item	Interval	Elapse Count	Alarm
Asle Planetary Ge...	100	2 0	🔔
Transmission Oil	100	2 0	🔔
Transmission Oil F...	100	2 0	🔔
Hydraulic Tank Al...	250	2 0	🔔
Air Cleaner Comp...	450	2 0	🔔
Engine Oil Filter	500	2 0	🔔

Maintenance Management
Display

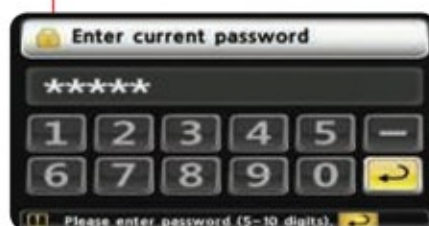

Password Starting System
(Anti-theft system)



Fuel Cover with Key

New 9 Series

Mast Specification (35D-9)

Mast Type		Maximum Fork Height	Overall Height (Lowered)		Free Lift Height		Tilt Angle		Load Capacity without side shift		Load Capacity with side shift		Truck Weight (Unloaded)	
			Single Tire	Double Tire	With Load Backrest	Without Load Backrest	Fwd	Bwd	Single Tire	Double Tire	Single Tire	Double Tire	Single Tire	Double Tire
			mm	mm	mm	mm	deg	deg	600 mm LC	600 mm LC	600 mm LC	600 mm LC	kg	kg
2-STAGE LIMITED FREE LIFT	V270	2720	2085	2070	120	120	8	10	3500	3500	3500	3500	5904	6059
	× V300	3020	2235	2220	120	120	8	10	3500	3500	3500	3500	5934	6089
	V330	3320	2385	2370	120	120	8	10	3500	3500	3500	3500	5972	6127
	V350	3520	2535	2520	120	120	8	10	3500	3500	3500	3500	5995	6150
	V370	3720	2635	2620	120	120	8	10	3500	3500	3500	3500	6015	6170
	V400	4020	2845	2830	120	120	8	10	3500	3500	3400	3450	6057	6212
	V430	4320	2995	2980	120	120	8	10	3500	3500	3350	3400	6087	6242
	V450	4520	3095	3080	120	120	8	6	3500	3500	3300	3350	6170	6325
	V500	5020	3345	3330	120	120	8	6	3400	3500	3200	3250	6221	6376
2-STAGE FULL FREE LIFT	VF280	2805	2135	2120	931	1258	8	8	3500	3500	3500	3500	5945	6097
	VF300	3005	2235	2220	1031	1358	8	8	3500	3500	3500	3500	5971	6123
	VF315	3155	2325	2310	1121	1448	8	8	3500	3500	3500	3500	5990	6143
3-STAGE FULL FREE LIFT	TF/TS370	3730	2035	2020	822	1149	8	8	3500	3500	3350	3450	6161	6316
	TF/TS400	4030	2135	2120	922	1249	8	8	3500	3500	3300	3400	6191	6346
	TF/TS430	4330	2235	2220	1022	1349	8	8	3500	3500	3250	3350	6222	6377
	TF/TS450	4510	2295	2290	1082	1409	8	8	3500	3500	3200	3300	6241	6396
	TF/TS470	4720	2385	2390	1172	1499	8	8	3400	3500	3150	3250	6277	6432
	TF/TS500	5020	2485	2470	1272	1599	8	6	3300	3400	3100	3200	6300	6455
	TF/TS550	5520	2665	2650	1452	1779	8	6	3200	3300	2850	3100	6361	6516
	TF/TS600	6030	2845	2830	1632	1959	8	6	3100	3200	2450	3000	6430	6585
	TF/TS650	6540	3025	3010	1812	2139	8	6	3000	3000	2350	2900	6471	6626

Mast Specification (40D-9)

Mast Type		Maximum Fork Height	Overall Height (Lowered)		Free Lift Height		Tilt Angle		Load Capacity without side shift		Load Capacity with side shift		Truck Weight (Unloaded)	
			Single Tire	Double Tire	With Load Backrest	Without Load Backrest	Fwd	Bwd	Single Tire	Double Tire	Single Tire	Double Tire	Single Tire	Double Tire
			mm	mm	mm	mm	deg	deg	600 mm LC	600 mm LC	600 mm LC	600 mm LC	kg	kg
2-STAGE LIMITED FREE LIFT	V270	2720	2085	2070	120	120	8	10	4000	4000	4000	4000	6348	6454
	× V300	3020	2235	2220	120	120	8	10	4000	4000	4000	4000	6378	6484
	V330	3320	2385	2370	120	120	8	10	4000	4000	4000	4000	6416	6522
	V350	3520	2535	2520	120	120	8	10	4000	4000	4000	4000	6439	6545
	V370	3720	2635	2620	120	120	8	10	4000	4000	3950	3950	6459	6565
	V400	4020	2845	2830	120	120	8	10	4000	4000	3900	3900	6502	6608
	V430	4320	2995	2980	120	120	8	10	4000	4000	3850	3850	6531	6637
	V450	4520	3095	3080	120	120	8	6	4000	4000	3800	3800	6614	6720
	V500	5020	3345	3330	120	120	8	6	3900	4000	3700	3700	6665	6771
2-STAGE FULL FREE LIFT	VF280	2805	2135	2120	916	1243	8	8	4000	4000	4000	4000	6389	6492
	VF300	3005	2235	2220	1016	1343	8	8	4000	4000	4000	4000	6415	6518
	VF315	3155	2325	2310	1106	1433	8	8	4000	4000	4000	4000	6434	6537
3-STAGE FULL FREE LIFT	TF/TS370	3730	2035	2020	807	1134	8	8	4000	4000	3900	3950	6605	6676
	TF/TS400	4030	2135	2120	907	1234	8	8	4000	4000	3850	3850	6635	6706
	TF/TS430	4330	2235	2220	1007	1334	8	8	4000	4000	3800	3800	6666	6737
	TF/TS450	4510	2295	2290	1067	1394	8	8	4000	4000	3800	3800	6685	6756
	TF/TS470	4720	2385	2390	1157	1484	8	8	4000	4000	3700	3750	6721	6792
	TF/TS500	5020	2485	2470	1257	1584	8	6	3900	3900	3600	3650	6744	6815
	TF/TS550	5520	2665	2650	1437	1764	8	6	3700	3800	3350	3500	6805	6876
	TF/TS600	6030	2845	2830	1617	1944	8	6	3600	3600	2950	3400	6874	6945
	TF/TS650	6540	3025	3010	1797	2124	8	6	3500	3500	2850	3300	6915	6986

Mast Specification (45D-9)

Mast Type		Maximum Fork Height	Overall Height (Lowered)		Free Lift Height		Tilt Angle		Load Capacity without side shift		Load Capacity with side shift		Truck Weight (Unloaded)	
			Single Tire	Double Tire	With Load Backrest	Without Load Backrest	Fwd	Bwd	Single Tire	Double Tire	Single Tire	Double Tire	Single Tire	Double Tire
			mm	mm	mm	mm	deg	deg	600 mm LC	600 mm LC	600 mm LC	600 mm LC	kg	kg
2-STAGE LIMITED FREE LIFT	V270	2720	2085	2070	120	120	8	10	4500	4500	4500	4500	6744	6870
	※ V300	3020	2235	2220	120	120	8	10	4500	4500	4500	4500	6774	6900
	V330	3320	2385	2370	120	120	8	10	4500	4500	4500	4500	6812	6938
	V350	3520	2535	2520	120	120	8	10	4500	4500	4500	4500	6835	6961
	V370	3720	2635	2620	120	120	8	10	4500	4500	4400	4400	6855	6981
	V400	4020	2845	2830	120	120	8	10	4500	4500	4350	4350	6897	7023
	V430	4320	2945	2980	120	120	8	10	4500	4500	4300	4300	6927	7053
	V450	4520	3095	3080	120	120	8	6	4500	4500	4200	4200	7010	7136
	V500	5020	3345	3330	120	120	8	6	4400	4400	4050	4050	7061	7187
2-STAGE FULL FREE LIFT	VF280	2805	2135	2120	853	1442	8	8	4500	4500	4500	4500	6780	6906
	VF300	3005	2235	2220	953	1542	8	8	4500	4500	4500	4500	6806	6932
	VF315	3155	2325	2310	1043	1602	8	8	4500	4500	4500	4500	6825	6951
3-STAGE FULL FREE LIFT	TF/TS370	3730	2035	2020	796	1114	8	8	4500	4500	4350	4350	7001	7129
	TF/TS400	4030	2135	2120	896	1214	8	8	4500	4500	4300	4300	7031	7159
	TF/TS430	4330	2235	2220	996	1314	8	8	4500	4500	4200	4200	7062	7190
	TF/TS450	4510	2295	2290	1056	1374	8	8	4500	4500	4150	4150	7081	7209
	TF/TS470	4720	2385	2390	1145	1484	8	8	4400	4400	4100	4100	7117	7246
	TF/TS500	5020	2485	2470	1246	1564	8	6	4300	4300	4000	4000	7140	7269
	TF/TS550	5520	2665	2650	1426	1744	8	6	4200	4200	3850	3850	7202	7330
	TF/TS600	6030	2845	2830	1606	1924	8	6	4000	4000	3250	3750	7270	7398
TF/TS650	6540	3025	3010	1786	2104	8	6	3900	3900	3150	3650	7312	7440	

Mast Specification (50D-9)

Mast Type		Maximum Fork Height	Overall Height (Lowered)		Free Lift Height		Tilt Angle		Load Capacity without side shift		Load Capacity with side shift		Truck Weight (Unloaded)	
			Single Tire	Double Tire	With Load Backrest	Without Load Backrest	Fwd	Bwd	Single Tire	Double Tire	Single Tire	Double Tire	Single Tire	Double Tire
			mm	mm	mm	mm	deg	deg	600 mm LC	600 mm LC	600 mm LC	600 mm LC	kg	kg
2-STAGE LIMITED FREE LIFT	V260	2630	2085	2070	120	120	8	10	5000	5000	5000	5000	7176	7291
	※ V290	2930	2235	2220	120	120	8	10	5000	5000	5000	5000	7201	7317
	V320	3230	2385	2370	120	120	8	10	5000	5000	5000	5000	7226	7342
	V340	3430	2535	2520	120	120	8	10	5000	5000	4950	4950	7251	7366
	V360	3630	2635	2620	120	120	8	10	5000	5000	4900	4900	7267	7383
	V390	3930	2845	2830	120	120	8	10	5000	5000	4800	4800	7303	7418
	V440	4430	3095	3080	120	120	8	6	4900	5000	4650	4650	7406	7522
	V490	4930	3345	3330	120	120	8	6	4800	4900	4500	4500	7448	7564
2-STAGE FULL FREE LIFT	VF270	2702	2135	2120	905	1223	8	8	5000	5000	4700	4750	7235	7347
	VF290	2902	2235	2220	1005	1323	8	8	5000	5000	4650	4700	7260	7372
	VF305	3052	2325	2310	1095	1413	8	8	5000	5000	4550	4600	7278	7390
3-STAGE FULL FREE LIFT	TF/TS360	3672	2035	2020	807	1074	8	8	5000	5000	4700	4800	7419	7523
	TF/TS390	3972	2135	2120	907	1174	8	8	5000	5000	4650	4700	7445	7549
	TF/TS420	4272	2235	2220	1007	1274	8	8	4900	5000	4550	4600	7470	7574
	TF/TS440	4452	2295	2280	1067	1334	8	8	4800	5000	4500	4550	7487	7590
	TF/TS460	4662	2385	2370	1157	1424	8	8	4700	4900	4450	4500	7510	7614
	TF/TS490	4962	2485	2470	1257	1524	8	6	4600	4800	4350	4450	7535	7639
	TF/TS540	5462	2665	2650	1437	1704	8	6	4500	4700	4250	4300	7587	7691
	TF/TS590	5972	2845	2830	1617	1884	8	6	4400	4600	4100	4200	7628	7731
TF/TS640	6482	3025	3010	1797	2064	8	6	4300	4500	4000	4100	7669	7773	

New 9 Series

Dimensions



Specifications

Identification						
1.1	Manufacturer	HYUNDAI				
1.2	Type	35D-9	40D-9	45D-9	50DA-9	
1.3	Drive: Electric, Diesel, LPG Gas	Diesel	Diesel	Diesel	Diesel	
1.4	Type of operation: hand, pedestrian, standing, seated, order-picker	seated	seated	seated	seated	
1.5	Load capacity / Rated load	Q (kg)	3,500	4,000	4,500	5,000
1.6	Load center distance	c (mm)	600	600	600	600
1.8	Load distance, center of drive axle to forks	x (mm)	561	561	561	576
1.9	Wheelbase	y (mm)	2,000	2,000	2,000	2,000
Weights						
2.1	Service weight	kg	5,934	6,484	6,900	7,317
2.2	Axle loading, loaded front / rear	kg	8,141 / 1,293	9,107 / 1,376	9,891 / 1,509	10,678 / 1,638
2.3	Axle loading, unloaded front / rear	kg	2,611 / 3,323	2,787 / 3,696	2,781 / 4,119	2,778 / 4,538
Wheels, Chassis						
3.1	Tires : Pneumatic(P), Solid(S), Non-marking(N)		P	P	P	P
3.2	Tires size, front		8.25-15-14PR	7.50-16-12PR	7.50-16-12PR	7.50-16-12PR
3.3	Tires size, rear		7.00-12-12PR	7.00-12-12PR	7.00-12-14PR	7.00-12-14PR
3.5	Wheels, number front / rear (x = driven wheels)		2 x 2	4 x 2	4 x 2	4 x 2
3.6	Track width, front	b10 (mm)	1,132	1,282	1,282	1,282
3.7	Track width, rear	b11 (mm)	1,140	1,140	1,140	1,140
Basic Dimensions						
4.1	Mast / fork carriage tilt forward / backward (α / β)	degrees	8 / 10	8 / 10	8 / 10	8 / 10
4.2	Lowered mast height	h1 (mm)	2,235	2,220	2,220	2,220
4.3	Free lift	h2 (mm)	120	120	120	120
4.4	Lift height (standard)	h3 (mm)	3,020	3,020	3,020	2,930
4.5	Extended mast height	h4 (mm)	4,234	4,234	4,234	4,147
4.7	Overhead load guard (cabin) height	h5 (mm)	2,220 (2,360)	2,210 (2,350)	2,210 (2,350)	2,210 (2,350)
4.8	Seat height / standing height rel. to SIP	h7 (mm)	1,070	1,070	1,070	1,070
4.12	Coupling height	h10 (mm)	364	364	364	364
4.19	Overall length	l1 (mm)	4,295	4,295	4,484	4,500
4.20	Length to face of forks	l2 (mm)	3,225	3,225	3,264	3,300
4.21	Overall width	b1 (mm)	1,370	1,740	1,740	1,740
4.22	Fork dimensions (hook type) LxWxT	s / e / t (mm)	1,070 x 122 x 50	1,070 x 150 x 50	1,220 x 150 x 50	1,200 x 150 x 60
4.23	Fork carriage ISO 2328, class / type A,B		III / A	III / A	IV / A	IV / A
4.24	Fork carriage width	b3 (mm)	1,300	1,600	1,600	1,600
4.31	Ground clearance, loaded, under mast	m1 (mm)	170	155	155	155
4.32	Ground clearance, centre of wheelbase	m2 (mm)	200	185	185	185
4.33	Aisle width for pallets 1000 x 1200 crossways (L x W)	Ast (mm)	4,711	4,711	4,751	4,784
4.34	Aisle width for pallets 800 x 1200 lengthways (W x L)	Ast (mm)	4,911	4,911	4,951	4,984
4.35	Turning radius	Wa (mm)	2,950	2,950	2,990	3,008
4.36	Internal turning radius	b13 (mm)	1,009	1,009	1,009	1,009
Performance Data						
5.1	Travel speed, unloaded	km/h	26.6	25.7	25.6	25.6
5.2	Lift speed, loaded / unloaded	mm/s	510 / 540	500 / 540	490 / 540	420 / 460
5.3	Lowering speed, loaded / unloaded	mm/s	500 / 500	500 / 500	500 / 500	500 / 500
5.5	Drawbar pull, loaded	kg	3,970	3,994	4,000	4,006
5.7	Gradient performance, loaded	%	40.9	36.4	33.2	30.6
5.10	Service brake		FOOT	FOOT	FOOT	FOOT
Engine						
6.1	Engine manufacturer / type		CUMMINS QSF3.8	CUMMINS QSF3.8	CUMMINS QSF3.8	CUMMINS QSF3.8
6.2	Engine power acc. To ISO 1585	ps/rpm	102 / 2,200	102 / 2,200	102 / 2,200	102 / 2,200
6.3	Maximum Torque	kg.f.m/rpm	42.3 / 1,600	42.3 / 1,600	42.3 / 1,600	42.3 / 1,600
6.4	No. of cylinder / cubic capacity	EA/cc	4 / 3,726	4 / 3,726	4 / 3,726	4 / 3,726
6.5	Fuel consumption acc. to VDI cycle	ℓ/h	6.1	6.2	6.4	6.5
Other Details						
8.1	Type of drive control		Power Shift 2/2	Power Shift 2/2	Power Shift 2/2	Power Shift 2/2
8.2	Operating pressure (system/attachments)	kg.f/cm ²	210 / 150	210 / 150	210 / 150	210 / 150
8.3	Hydraulic oil flow (attachments)	ℓ	100	100	100	100

35/40/45D-9 50DA-9

Load Capacity

35D-9

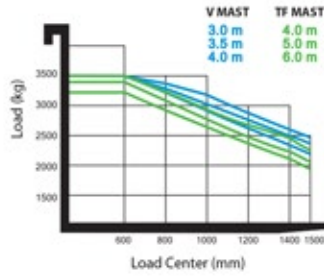

40D-9

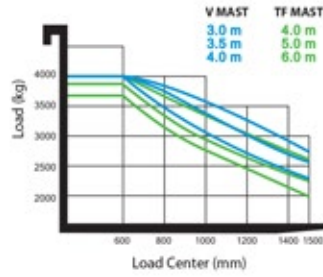

45D-9

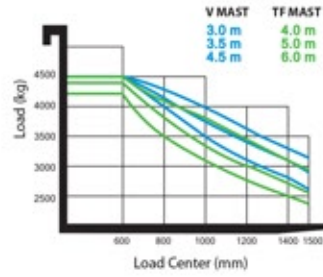

50DA-9

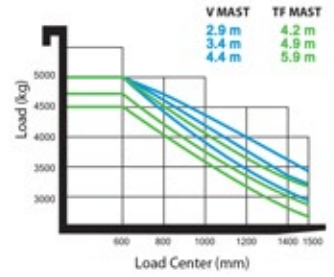

- * Standard and optional equipment may vary per country. Contact your Hyundai dealer for more information.
- * The photos may include attachments and optional equipment that are not available in your area.
- * Materials and specifications are subject to change without advance notice.
- * All imperial measurements rounded off to the nearest pound or inch.



Hyundai Heavy Industries Europe N.V.
VOSSENDAAL 11, 2440 GEEL, BELGIUM TEL: (32) 14-56-2200 FAX: (32) 14-59-3405

PLEASE CONTACT



N.D.L.T. 30 Burkitt Road
Earlstrees Industrial Estate
Corby
Northants
NN17 4DT

TEL: **01536 201755**
Email: info@ndltcorby.co.uk

www.hyundai.eu

EN - 2016.02 Rev 0