

# 50/70D/80D-9

Diesel Counterbalance Trucks

MOVING YOU FURTHER

HYUNDAI HEAVY INDUSTRIES



■ Photo may include optional equipment

 **HYUNDAI**

---

# Your satisfaction is **our priority!**

Hyundai introduces a new line of **9-series** diesel forklift trucks.  
The newly designed 4 wheel counterbalance trucks provide every operator  
comfortable driving, increased productivity and easy maintenance.

---



---

## **New Diesel Forklift with Proven Quality and Advanced Technology**

- **Maximum performance**
- **Spacious operator's cab**
- **Switch type parking brake**
- **4.3 inch LCD color cluster**
- **Truck inclination warning system**
- **OPSS System for safe operation**
- **Easy serviceability**
- **Max speed limit function**
- **Password starting system**
- **Weight indicator (Optional)**
- **FATC (Full Automatic Temperature Control) (Optional)**



■ Photo may include optional equipment



# High Efficiency & **Optimal Performance**



■ Photo may include optional equipment

## **CUMMINS QSF3.8 Engine**

**75 kW / 2,200 rpm**

**42.3 kgf·m / 1,600 rpm**



### **Powerful Engine**

The 4 cylinders turbo-charged engine is built for power, reliability and economy. This engine meets EPA Tier 4 Final and EU stage IV emission regulation.

### **Excellent Fuel Efficiency**

Fuel consumption rate is improved than previous model.

### **SCR (Selective Catalytic Reduction)**

### **EGR (Exhaust Gas Recirculation)**

- High torque at low speeds
- Excellent transient behavior

Powerful engine and high technology systems provide you with enhanced performance and highest productivity.

# 50/70D/80D-9



### Highly Durable Drive Axle

The strengthened drive axle separable from transmission ensures low vibration and easy maintenance. The wet disc type brake is applied for easy operation, smooth response and maintenance free.



### Negative Parking brake system

Multi wet discs type parking brake provides effective brake performance and easy operation by switch.



### Highly Durable Transmission

Powershift transmission of forward 2 stages and reverse 2 stages provides fast travel speed and quiet travel under any heavy load condition, and enhances work efficiency. The clutch protection system prevents excessive use of inching as well as minimizes change-impact.



### Fully hydrostatic power steering

The hydraulic steering system always guarantees smooth and flexible steering, preventing overrun and kick-back.

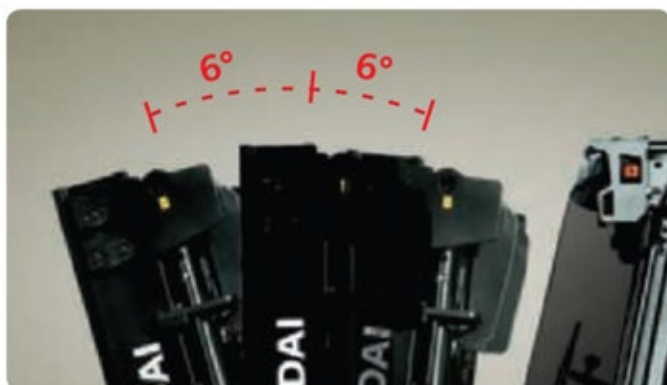

### Increased Mast Tilting Angle

The mast tilting angle of 6 degrees forward and 6 degrees backward, the operator can perform loading and unloading jobs safely and rapidly.



### Max. Travel Speed

Model	Km / h (mph)
50D-9	33.9 (21)
70D-9	33.6 (20.8)
80D-9	35

### Max. Gradeability

Model	%
50D-9	58.7
70D-9	44.4
80D-9	35.2 / 26.5

### Faster Travel Speed and Gradeability

The powerful high-output engine provides greater acceleration, better gradeability and faster travel speed on any tough terrain or slope.



# Best Convenience & Optimized Ergonomics



## Spacious Operator Cabin

■ Photo may include optional equipment

The newly designed cabin provides wide visibility and spacious environment, ensuring all day comfort for the operator.



## Centralized Instrument Switch Panel



## Quick Response of Operating Control Levers

Only minimal operator's effort is required for precise, safe and productive control.  
(4 Lever : Standard), (2/3/5 Lever : Optional)



## Optimized Pedal Position



## Multi-Function Switch Lever



## Grammer Seat (STD)

An attractive and adjustable seat, based on a human engineering design, provides great comfort. And the angle of the armrest can be adjusted to reduce the fatigue of the driver.

- Applied the weight of the driver (45~170 kg)
- ELR type seat belt standard
- Heater and Head Rest (Option)

A design based on human engineering relieves fatigue and increases operator's efficiency.

# 50/70D/80D-9



## New design and Concentrated Cluster Panel

1	Parking lamp	9	Hour meter	17	Rear wheel angle (option)
2	Engine check warning lamp	10	Odometer	18	Right turn signal indicator lamp
3	High beam indicator lamp	11	Outside temperature indicator	19	Engine coolant temperature gauge
4	Operator presence indicator lamp	12	Air-con setting temp. indicator	20	Transmission oil temperature gauge
5	Seat belt warning lamp	13	Vehicle tilt angle indicator	21	Fuel gauge
6	Left turn signal indicator lamp	14	Clock	22	Speed gauge
7	Engine RPM indicator	15	T/M information display		
8	Load weight indicator(option)	16	Urea level gauge		



### Full Automatic Temperature Control

The system automatically controls the temperature of a cabin to maintain the optimal working environment.

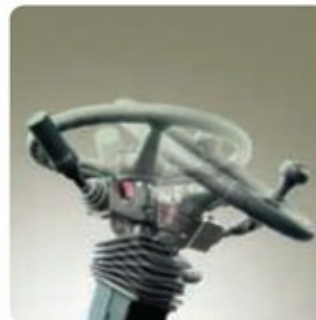

### Adjustable Steering Wheel

Steering wheel with horn button can be adjusted by a lever on the right-hand side for the most comfortable operator position.





# Advanced **Safety**



## Electrical Interlock

When parking brake engaged travel electric power intercepted. Even if when forward or reverse lever operated, vehicle can't be traveled.



## Adjustable Engine Low Idle RPM

While engine runs, low idle rpm can be increased by unit of 25rpm and it keeps previously set rpm when engine restarts.

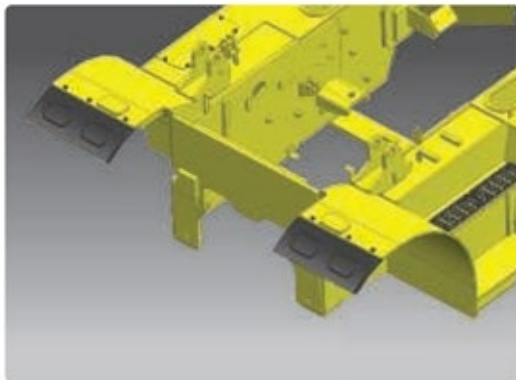

## Front Mudguard STD.

Front mud guard protect the equipment from foreign substances caused by the front tires. It helps to use the equipment clearly.

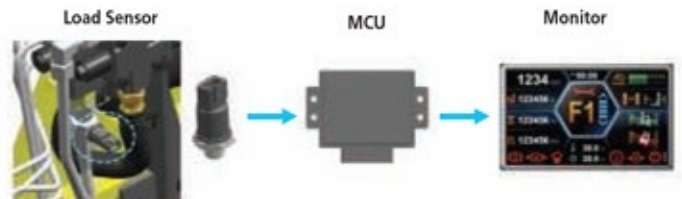

## Weight Indicator (Optional)

The optional load indicator displays the load weight on the monitor. The load sensor reduces the time to check loaded weight and the alarm alerts the driver when overloaded.



## Efficient Cooling System

Aluminum radiator provides excellent cooling capacity with improved air flow.



## Large Footboard & Hand Grip

Wide "open" step offers convenience and safety when entering and exiting truck.

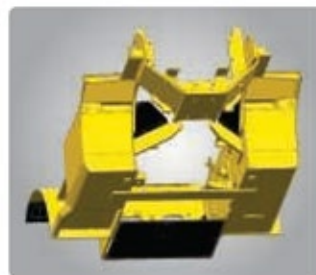

## Rear Tire Cover/ Under Cover (Optional)

The cover protect the engine and components from damage caused foreign substances.



## Easy and Safe Shift Lever

A single lever on the left side of the steering column gives the operator fast, easy control of direction. The lever must be in the neutral position before the engine can be started.



The safely designed driver's space makes your operating more comfortable.

## 50/70D/80D-9

### Fork safety features

When the forks are being lowered, a down-control valve maintains the controlled speed. The down-safety valve prevents forks from dropping down in case of sudden damage of hydraulic line.

### OPSS (Operator Presence Sensing System)

When the operator is not in the seat all mast and drive movements are impossible.



■ Photo may include optional equipment



### Bright, Protected Headlights / Full lighting

In order to provide the driver exceptional visibility in all circumstances, work lamps are standard both to the front and to the back.



### Expansion Bellows

Sufficient length of bellows pipe between exhaust pipe and engine exhaust manifold certifies the durability of muffler and exhaust pipe.



### Grease Fittings

Grease fittings are installed for fast access to steering axle center pin when doing your service checks.

# Fast and Easy Maintenance



## Enlarged Engine Hood Cover

Highly accessible engine compartment assures fast and efficient maintenance.

■ Photo may include optional equipment



## Cab Tilt System

The cab tilt system makes servicing of all powertrain components quick and easy. An electrically assisted hydraulic actuated cylinder tilts operator cab to left side about 54 degrees for access to open truck components.



## Mechanic friendly Pre-Fuel Filter Replacement

Highly accessible engine compartment allows for quick replacement of filters.



## Electrically Monitored Air Filter Easy-to-Access

Air cleaner sensor alerts the operator of a clogged air filter and allows replacement before damage.



## Waterproof & Dustproof Cover

Newly developed Waterproof and Dustproof fuse box and relay box for ease of maintenance.



An ideal arrangement of components ensures easy access and convenience for maintenance.

## 50/70D/80D-9

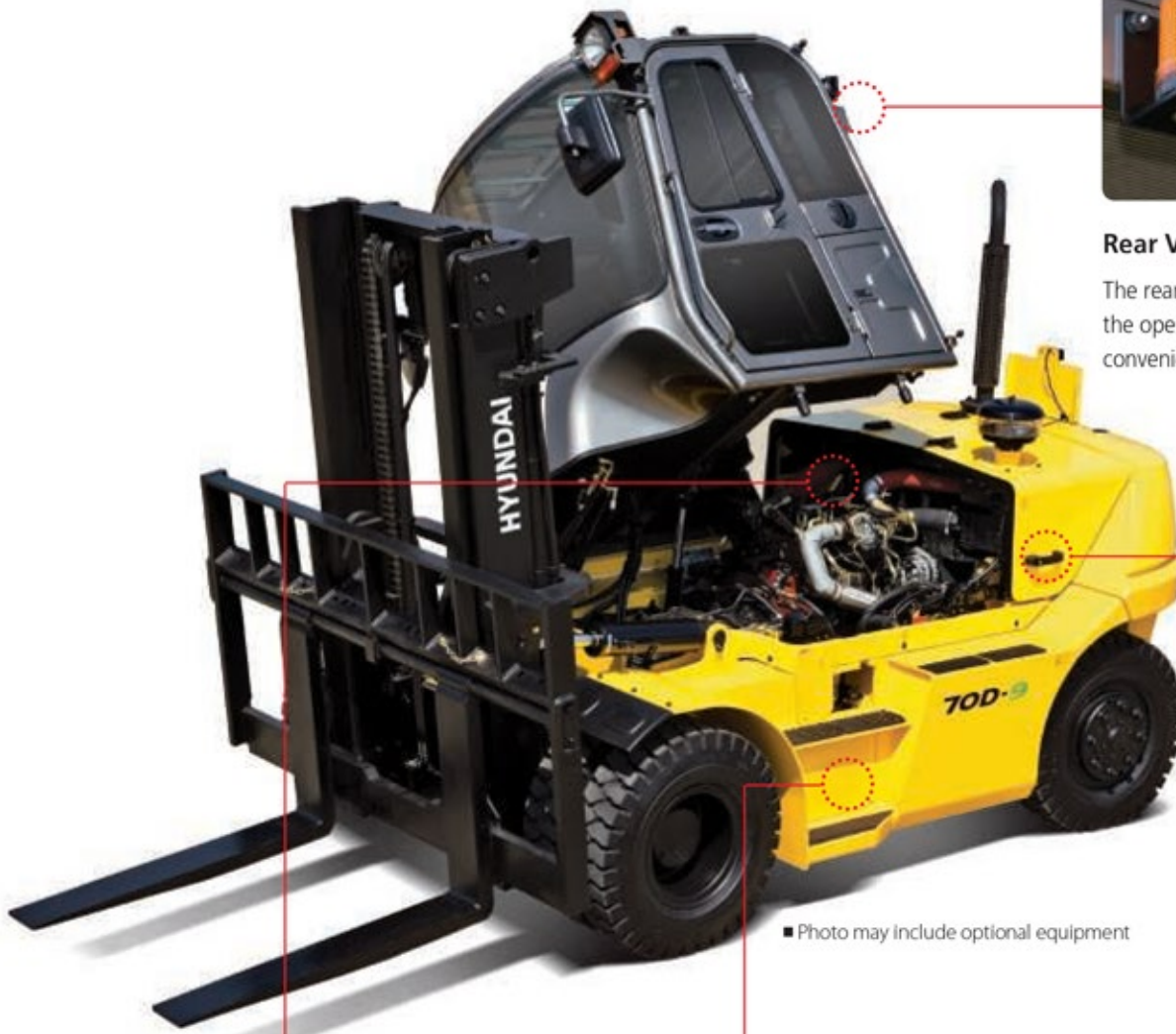

### Rear View Camera

The rear view camera makes the operation more easy and convenient.

■ Photo may include optional equipment



Easy-to-Access Washer Tank



Maintenance Free Batteries



Wing Cover Locking System

# New 9 Series

## Mast Specification (50D-9) Standard : Hook-On Type Fork & Carriage

Mast Type	Maximum Fork Height	Overall Height								Free Lift				Tilt Angle		Load Capacity w/o Side Shift At 24 in (600mm)LC		Load Capacity w/ Side Shift At 24 in (600mm)LC		Truck Weight Unloaded	
		Lowered		Extended				Without Load Backrest		With Std Load Backrest		Fwd	Bwd								
				in	mm	in	mm							in	mm	in	mm	deg	deg	lb	kg
2- Stage Limited free lift	V270	107	2730	93	2365	145	3691	158	4020	6	140	6	140	6	6	11000	5000	11000	5000	19548	8865
	*V300	119	3030	99	2515	157	3991	170	4320	6	140	6	140	6	6	11000	5000	11000	5000	19654	8913
	V330	131	3330	105	2665	169	4291	182	4620	6	140	6	140	6	6	11000	5000	11000	5000	19760	8961
	V350	139	3530	109	2765	177	4491	190	4820	6	140	6	140	6	6	11000	5000	11000	5000	19828	8992
	V370	147	3730	113	2865	185	4691	198	5020	6	140	6	140	6	6	11000	5000	11000	5000	19899	9024
	V400	159	4030	119	3015	196	4991	209	5320	6	140	6	140	6	6	11000	5000	11000	5000	20022	9080
	V450	178	4530	131	3315	216	5491	229	5820	6	140	6	140	6	6	11000	5000	11000	5000	20525	9308
	V500	198	5030	140	3565	236	5991	249	6320	6	140	6	140	6	6	11000	5000	11000	5000	20701	9388
	V550	218	5530	150	3815	256	6491	269	6820	6	140	6	140	6	6	11000	5000	11000	5000	20875	9467
	V600	237	6030	160	4065	275	6991	288	7320	6	140	6	140	6	6	11000	5000	11000	5000	21050	9546
3- Stage full free lift	TF/TS450	180	4560	101	2565	218	5545	229	5805	62	1580	50	1275	6	6	11000	5000	11000	5000	21006	9526
	TF/TS500	199	5060	227	5765	238	6045	248	6305	70	1780	58	1475	6	6	11000	5000	11000	5000	21208	9618
	TF/TS560	220	5600	117	2965	259	6585	269	6845	78	1980	66	1675	6	6	11000	5000	10805	4900	21453	9729
	TF/TS600	239	6060	125	3165	277	7045	288	7305	86	2180	74	1875	6	6	10805	4900	10584	4800	21647	9817

## Mast Specification (50D-9) Option : Shaft Type Fork & Carriage

Mast Type	Maximum Fork Height	Overall Height								Free Lift				Tilt Angle		Load Capacity w/o Side Shift At 24 in (600mm)LC		Load Capacity w/ Side Shift At 24 in (600mm)LC		Truck Weight Unloaded	
		Lowered		Extended				Without Load Backrest		With Std Load Backrest		Fwd	Bwd								
				in	mm	in	mm							in	mm	in	mm	deg	deg	lb	kg
2- Stage Limited free lift	V270	107	2730	93	2365	-	-	156	3975	-	-	6	140	6	6	11000	5000	-	-	19497	8842
	*V300	119	3030	99	2515	-	-	168	4275	-	-	6	140	6	6	11000	5000	-	-	19603	8890
	V330	131	3330	105	2665	-	-	180	4575	-	-	6	140	6	6	11000	5000	-	-	19709	8938
	V350	139	3530	109	2765	-	-	188	4775	-	-	6	140	6	6	11000	5000	-	-	19777	8969
	V370	147	3730	113	2865	-	-	196	4975	-	-	6	140	6	6	11000	5000	-	-	19848	9001
	V400	159	4030	119	3015	-	-	208	5275	-	-	6	140	6	6	11000	5000	-	-	19971	9057
	V450	178	4530	131	3315	-	-	227	5775	-	-	6	140	6	6	11000	5000	-	-	20474	9285
	V500	198	5030	140	3565	-	-	247	6275	-	-	6	140	6	6	11000	5000	-	-	20650	9365
	V550	218	5530	150	3815	-	-	267	6775	-	-	6	140	6	6	11000	5000	-	-	20825	9444
	V600	237	6030	160	4065	-	-	286	7275	-	-	6	140	6	6	11000	5000	-	-	20999	9523
3- Stage full free lift	TF/TS450	180	4560	101	2565	-	-	229	5805	-	-	52	1320	6	6	11000	5000	-	-	20853	9457
	TF/TS500	199	5060	227	5765	-	-	248	6305	-	-	60	1520	6	6	11000	5000	-	-	21056	9549
	TF/TS560	220	5600	117	2965	-	-	269	6845	-	-	68	1720	6	6	11000	5000	-	-	21301	9660
	TF/TS600	239	6060	125	3165	-	-	288	7305	-	-	76	1920	6	6	10805	4900	-	-	21495	9748



## Mast Specification (70D-9) Standard : Hook-On Type Fork & Carriage

Mast Type	Maximum Fork Height		Overall Height						Free Lift				Tilt Angle		Load Capacity w/o Side Shift At 24 in (600mm)LC		Load Capacity w/ Side Shift At 24 in (600mm)LC		Truck Weight Unloaded		
			Lowered		Extended				Without Load Backrest		With Std Load Backrest		Fwd	Bwd							
					W/o Load Backrest		W/Std Load Backrest														
in	mm	in	mm	in	mm	in	mm	in	mm	in	mm	deg	deg	lb	kg	lb	kg	lb	kg		
2- Stage Limited free lift	V270	107	2730	93	2365	154	3911	158	4020	6	140	6	140	6	6	15500	7000	15500	7000	22798	10339
	*V300	119	3030	99	2515	166	4211	170	4320	6	140	6	140	6	6	15500	7000	15500	7000	22902	10386
	V330	131	3330	105	2665	178	4511	182	4620	6	140	6	140	6	6	15500	7000	15500	7000	23008	10434
	V350	139	3530	109	2765	185	4711	190	4820	6	140	6	140	6	6	15500	7000	15500	7000	23078	10466
	V370	147	3730	113	2865	193	4911	198	5020	6	140	6	140	6	6	15500	7000	15500	7000	23149	10498
	V400	159	4030	119	3015	205	5211	209	5320	6	140	6	140	6	6	15500	7000	15500	7000	23272	10554
	V450	178	4530	131	3315	225	5711	229	5820	6	140	6	140	6	6	15500	7000	15500	7000	23773	10781
	V500	198	5030	140	3565	245	6211	249	6320	6	140	6	140	6	6	15500	7000	15500	7000	23949	10861
	V550	218	5530	150	3815	264	6711	269	6820	6	140	6	140	6	6	15500	7000	15500	7000	24123	10940
	V600	237	6030	160	4065	284	7211	288	7320	6	140	6	140	6	6	15500	7000	15500	7000	24298	11019
3- Stage full free lift	TF/TS450	180	4560	101	2565	227	5765	229	5805	54	1360	50	1275	6	6	15500	7000	15500	7000	24368	11051
	TF/TS500	199	5060	109	2765	247	6265	248	6305	61	1560	58	1475	6	6	15500	7000	15500	7000	24571	11143
	TF/TS560	220	5600	117	2965	268	6805	269	6845	69	1760	66	1675	6	6	15500	7000	15215	6900	24816	11254
	TF/TS600	239	6060	125	3165	286	7265	288	7305	77	1960	74	1875	6	6	14994	6800	14774	6700	25010	11342

## Mast Specification (70D-9) Option : Shaft Type Fork & Carriage

Mast Type	Maximum Fork Height		Overall Height						Free Lift				Tilt Angle		Load Capacity w/o Side Shift At 24 in (600mm)LC		Load Capacity w/ Side Shift At 24 in (600mm)LC		Truck Weight Unloaded		
			Lowered		Extended				Without Load Backrest		With Std Load Backrest		Fwd	Bwd							
					W/o Load Backrest		W/Std Load Backrest														
in	mm	in	mm	in	mm	in	mm	in	mm	in	mm	deg	deg	lb	kg	lb	kg	lb	kg		
2- Stage Limited free lift	V270	107	2730	93	2365	-	-	156	3975	-	-	6	140	6	6	15500	7000	-	-	22988	10425
	*V300	119	3030	99	2515	-	-	168	4275	-	-	6	140	6	6	15500	7000	-	-	23096	10474
	V330	131	3330	105	2665	-	-	180	4575	-	-	6	140	6	6	15500	7000	-	-	23200	10521
	V350	139	3530	109	2765	-	-	188	4775	-	-	6	140	6	6	15500	7000	-	-	23268	10552
	V370	147	3730	113	2865	-	-	196	4975	-	-	6	140	6	6	15500	7000	-	-	23338	10584
	V400	159	4030	119	3015	-	-	208	5275	-	-	6	140	6	6	15500	7000	-	-	23462	10640
	V450	178	4530	131	3315	-	-	227	5775	-	-	6	140	6	6	15500	7000	-	-	23965	10868
	V500	198	5030	140	3565	-	-	247	6275	-	-	6	140	6	6	15500	7000	-	-	24141	10948
	V550	218	5530	150	3815	-	-	267	6775	-	-	6	140	6	6	15500	7000	-	-	24315	11027
	V600	237	6030	160	4065	-	-	286	7275	-	-	6	140	6	6	15500	7000	-	-	24490	11106
3- Stage full free lift	TF/TS450	180	4560	101	2565	-	-	229	5805	-	-	52	1320	6	6	15500	7000	-	-	24395	11063
	TF/TS500	199	5060	109	2765	-	-	248	6305	-	-	60	1520	6	6	15500	7000	-	-	24598	11155
	TF/TS560	220	5600	117	2965	-	-	269	6845	-	-	68	1720	6	6	15500	7000	-	-	24842	11266
	TF/TS600	239	6060	125	3165	-	-	288	7305	-	-	76	1920	6	6	14994	6800	-	-	25036	11354

# New 9 Series

## Mast Specification (80D-9) Standard : Hook-On Type Fork & Carriage

Mast Type	Maximum Fork height	Overall Height								Free Lift				Tilt Angle		Load capacity w /o side shift At 24 in (600mm)LC		Load capacity w /integral side shift At 24 in (600mm)LC		Truck Weight Unloaded	
		Lowered				Extended				Without Load Backrest		With Std Load Backrest		Fwd	Bwd	lb	kg	lb	kg	lb	kg
		in		mm		W/o Load Backrest		W/Std Load Backrest		in		mm									
		in	mm	in	mm	in	mm	in	mm	in	mm	in	mm	deg	deg	lb	kg	lb	kg	lb	kg
2-Stage Limited Free lift	V270	107.9	2740	99.4	2525	159.4	4048	159.4	4050	5.9	150	5.9	150	6	6	17500	8000	17500	8000	25487	11559
	V300	119.7	3040	105.3	2675	171.2	4348	171.3	4350	5.9	150	5.9	150	6	6	17500	8000	17500	8000	25595	11608
	V330	131.5	3340	111.2	2825	183.0	4648	183.1	4650	5.9	150	5.9	150	6	6	17500	8000	17500	8000	25703	11657
	V350	139.4	3540	115.2	2925	190.9	4848	190.9	4850	5.9	150	5.9	150	6	6	17500	8000	17500	8000	25776	11690
	V370	147.2	3740	119.1	3025	198.7	5048	198.8	5050	5.9	150	5.9	150	6	6	17500	8000	17500	8000	25847	11722
	V400	159.1	4040	125.0	3175	210.6	5348	210.6	5350	5.9	150	5.9	150	6	6	17500	8000	17500	8000	25955	11771
	V450	178.7	4540	136.8	3475	230.2	5848	230.3	5850	5.9	150	5.9	150	6	6	17500	8000	17500	8000	26429	11986
	V500	198.4	5040	146.7	3725	249.9	6348	250.0	6350	5.9	150	5.9	150	6	6	17500	8000	17500	8000	26609	12067
	V550	218.1	5540	156.5	3975	269.6	6848	269.7	6850	5.9	150	5.9	150	6	6	17500	8000	16979	7700	26788	12149
	V600	237.8	6040	166.3	4225	289.3	7348	289.4	7350	5.9	150	5.9	150	6	6	17420	7900	16538	7500	26969	12231
	V700	277.2	7040	186.0	4725	328.7	8348	328.7	8350	5.9	150	5.9	150	6	6	16538	7500	15656	7100	27421	12436
V750	296.9	7540	195.9	4975	348.3	8848	348.4	8850	5.9	150	5.9	150	6	6	16097	7300	15215	6900	27606	12520	
3-Stage Full Free lift	TF/TS450	179.9	4570	108.3	2750	232.4	5902	231.5	5880	55.8	1418	56.7	1440	6	6	17500	8000	17500	8000	27055	12270
	TF/TS500	199.6	5070	116.1	2950	252.0	6402	251.2	6380	63.7	1618	64.6	1640	6	6	17500	8000	17200	7800	27282	12373
	TF/TS550	223.2	5670	124.0	3150	271.7	6902	270.9	6880	71.6	1818	72.4	1840	6	6	17500	8000	16759	7600	27507	12475
	TF/TS600	239.0	6070	131.9	3350	291.4	7402	290.6	7380	79.4	2018	80.3	2040	6	6	17200	7800	16318	7400	27734	12578

## Mast Specification (80D-9) Option : Shaft Type Fork & Carriage

Mast Type	Maximum Fork height	Overall Height						Free Lift		Tilt Angle		Load capacity w /o side shift At 24 in (600mm)LC		Load capacity w /integral side shift At 24 in (600mm) LC		Truck Weight Unloaded	
		Lowered			Extended			in		Fwd	Bwd	lb	kg	lb	kg	lb	kg
		in		mm		in		mm									
		in	mm	in	mm	in	mm	in	mm	deg	deg	lb	kg	lb	kg	lb	kg
2-Stage Limited Free lift	V270	107.9	2740	99.4	2525	160.4	4075	5.9	150	6	6	17500	8000	17500	8000	25461	11547
	V300	119.7	3040	105.3	2675	172.2	4375	5.9	150	6	6	17500	8000	17500	8000	25569	11596
	V330	131.5	3340	111.2	2825	184.1	4675	5.9	150	6	6	17500	8000	17500	8000	25677	11645
	V350	139.4	3540	115.2	2925	191.9	4875	5.9	150	6	6	17500	8000	17500	8000	25750	11678
	V370	147.2	3740	119.1	3025	199.8	5075	5.9	150	6	6	17500	8000	17500	8000	25820	11710
	V400	159.1	4040	125.0	3175	211.6	5375	5.9	150	6	6	17500	8000	17500	8000	25928	11759
	V450	178.7	4540	136.8	3475	231.3	5875	5.9	150	6	6	17500	8000	17500	8000	26402	11974
	V500	198.4	5040	146.7	3725	251.0	6375	5.9	150	6	6	17500	8000	17420	7900	26582	12055
	V550	218.1	5540	156.5	3975	270.7	6875	5.9	150	6	6	17500	8000	16979	7700	26762	12137
	V600	237.8	6040	166.3	4225	290.4	7375	5.9	150	6	6	17420	7900	16318	7400	26943	12219
	V700	277.2	7040	186.0	4725	329.7	8375	5.9	150	6	6	16538	7500	15436	7000	27395	12424
V750	296.9	7540	195.9	4975	349.4	8875	5.9	150	6	6	16097	7300	14994	6800	27580	12508	
3-Stage Full Free lift	TF/TS 450	179.9	4570	108.3	2750	232.5	5905	55.7	1415	6	6	17500	8000	17500	8000	26998	12244
	TF/TS 500	199.6	5070	116.1	2950	252.2	6405	63.6	1615	6	6	17500	8000	17200	7800	27225	12347
	TF/TS 550	223.2	5670	124.0	3150	271.9	6905	71.5	1815	6	6	17500	8000	16759	7600	27450	12449
	TF/TS 600	239.0	6070	131.9	3350	291.5	7405	79.3	2015	6	6	17200	7800	16318	7400	27677	12552



# 50/70D/80D-9

## Load Capacity

### 50D-9

#### HOOK TYPE

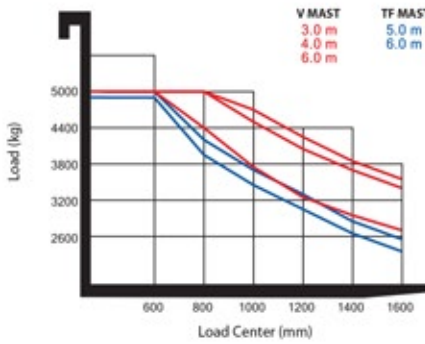

#### SHAFT TYPE

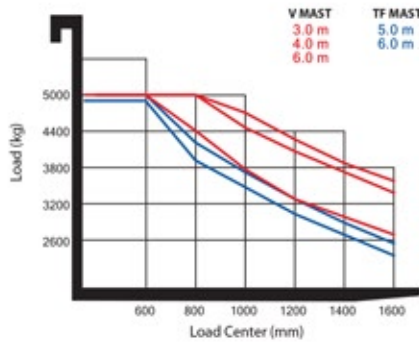

### 70D-9

#### HOOK TYPE

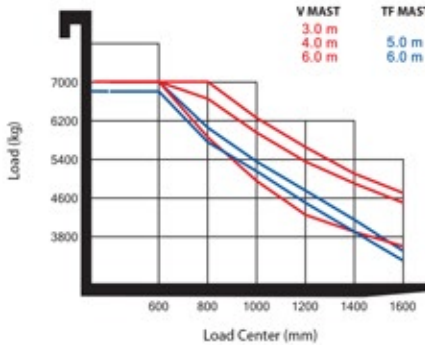

#### SHAFT TYPE

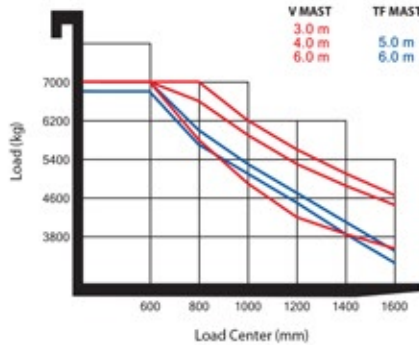

### 80D-9

#### HOOK TYPE

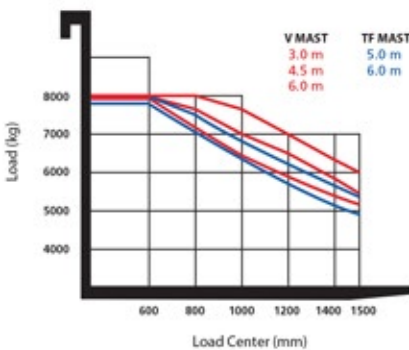

#### SHAFT TYPE

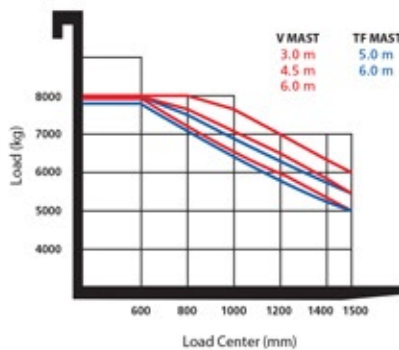

# New 9 Series

## Dimensions

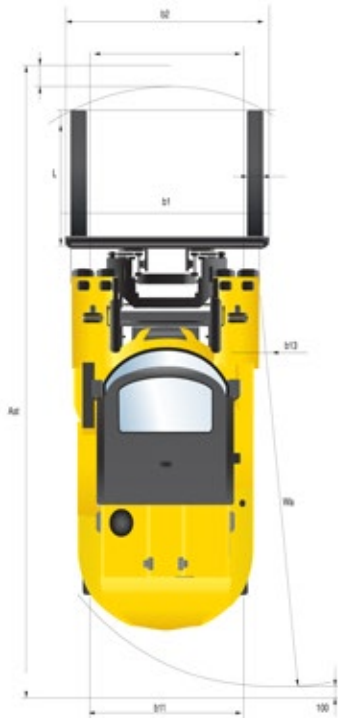

## Specifications

Identification				
1.1	Manufacturer	HYUNDAI		
1.2	Type	50D-9	70D-9	
1.3	Drive: Electric, Diesel, LPG Gas	Diesel	Diesel	
1.4	Type of operation: hand, pedestrian, standing, seated, order-picker	seated	seated	
1.5	Load capacity / Rated load	Q (kg)	5,000	7,000
1.6	Load center distance	c (mm)	600	600
1.8	Load distance, center of drive axle to forks	x (mm)	610	610
1.9	Wheelbase	y (mm)	2,300	2,300
Weights				
2.1	Service weight	kg	8,890	10,474
2.2	Axle loading, loaded front / rear	kg	12,153 / 1,692	15,126 / 2,273
2.3	Axle loading, unloaded front / rear	kg	4,509 / 4,335	4,426 / 5,972
Wheels, Chassis				
3.1	Tires : Pneumatic(P), Solid(S), Non-marking(N)		P	P
3.2	Tires size, front		8.25-15-14PR	8.25-15-14PR
3.3	Tires size, rear		8.25-15-14PR	8.25-15-14PR
3.5	Wheels, number front / rear (x = driven wheels)		4 x / 2	4 x / 2
3.6	Track width, front	b10 (mm)	1,580	1,580
3.7	Track width, rear	b11 (mm)	1,604	1,604
Basic Dimensions				
4.1	Mast / fork carriage tilt forward / backward (α / β)	degrees	6 / 6	6 / 6
4.2	Lowered mast height	h1 (mm)	2,515	2,515
4.3	Free lift	h2 (mm)	140	140
4.4	Lift height (standard)	h3 (mm)	3,030	3,030
4.5	Extended mast height	h4 (mm)	4,275	4,275
4.7	Overhead load guard (cabin) height	h5 (mm)	2,597	2,597
4.8	Seat height / standing height rel. to SIP	h7 (mm)	1,551	1,551
4.12	Coupling height	h10 (mm)	425	425
4.19	Overall length	l1 (mm)	4,716	4,866
4.20	Length to face of forks	l2 (mm)	3,516	3,666
4.21	Overall width	b1 (mm)	2,088	2,088
4.22	Fork dimensions (hook type) LxWxT	s / e / l (mm)	60 x 150 x 1,200	65 x 150 x 1,200
4.23	Fork carriage ISO 2328, class / type A,B		Class IV	Class IV
4.24	Fork carriage width	b3 (mm)	2,068	2,068
4.31	Ground clearance, loaded, under mast	m1 (mm)	195	195
4.32	Ground clearance, centre of wheelbase	m2 (mm)	199	191
4.33	Aisle width for pallets 1000 x 1200 crossways (L x W)	Ast (mm)	5,129	5,251
4.34	Aisle width for pallets 800 x 1200 lengthways (W x L)	Ast (mm)	5,329	5,451
4.35	Turning radius	Wa (mm)	3,314	3,436
4.36	Smallest pivot point distance	b13 (mm)	1,224	1,224
Performance Data				
5.1	Travel speed, unloaded	km/h	33.9	33.6
5.2	Lift speed, loaded / unloaded	mm/s	440 / 460	420 / 460
5.3	Lowering speed, loaded / unloaded	mm/s	500 / 450	500 / 450
5.5	Drawbar pull, loaded	kg	7,591	7,664
5.7	Gradient performance, loaded	%	58.7	44.4
5.10	Service brake		FOOT (Hydraulic)	FOOT (Hydraulic)
Engine				
6.1	Engine manufacturer / type		CUMMINS / QSF3.8	CUMMINS / QSF3.8
6.2	Engine power acc. To ISO 1585	kW (ps)/rpm	75 (102) / 2,200	75 (102) / 2,200
6.3	Maximum Torque	kg.f.m/rpm	42.3 / 1,600	42.3 / 1,600
6.4	No. of cylinder / cubic capacity	EA/cc	4 / 3,800	4 / 3,800
6.5	Fuel consumption acc. to VDI cycle	ℓ/h	8.1	8.3
Other Details				
8.1	Type of drive control		Full Auto	Full Auto
8.2	Operating pressure (system/attachments)	bar	185 / 150	185 / 150
8.3	Hydraulic oil flow (attachments)	ℓ	132	132
8.4	Sound pressure level (at driver's ear according to DIN 12053)	dB(A)	79.8	79.8
8.5	Trailer coupling, type DIN		Pin	Pin



# 50/70D/80D-9

## Dimension

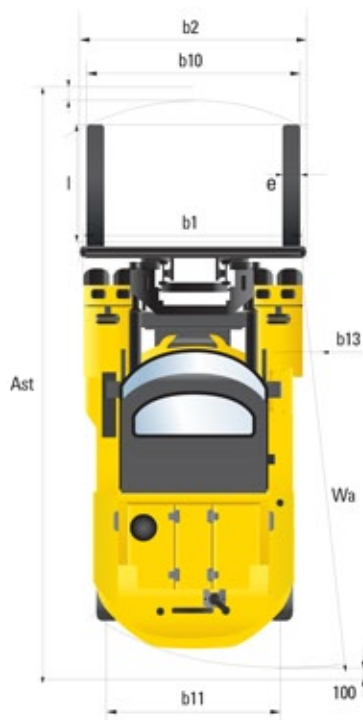
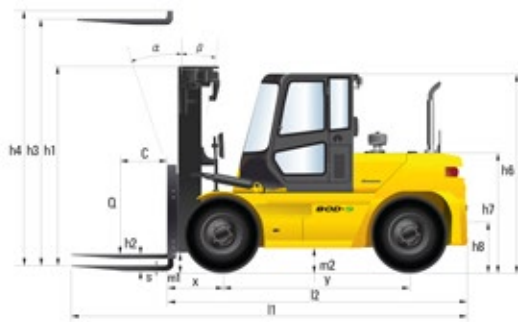

## Specification

Identification		
1.1	Manufacturer	Hyundai
1.2	Type	80D-9
1.3	Drive: electric (battery or mains), diesel, petrol, fuel gas, manual	DIESEL
1.4	Type of operation: hand, pedestrian, standing, seated, order-picker	seated
1.5	Load capacity (standard) / Rated load	Q (kg) 8,000
1.6	Load center distance	c (mm) 600
1.8	Load distance, center of drive axle to forks	x (mm) 690
1.9	Wheelbase	y (mm) 2,500
Weights		
2.1	Service weight	kg 11,608
2.2	Axle loading, loaded front / rear	kg 17,258 / 2,442
2.3	Axle loading, unloaded front / rear	kg 5,130 / 6,570
Wheels, Chassis		
3.1	Tires : Pneumatic (P), Solid (S), Non-marking (N)	pneumatic
3.2	Tires size, front	9.00-20-14PR
3.3	Tires size, rear	9.00-20-14PR
3.5	Number of wheels front / rear (x=driven wheels)	4 x / 2
3.6	Track width, front	b10 (mm) 1,632
3.7	Track width, rear	b11 (mm) 1,700
Basic Dimensions		
4.1	Mast / fork carriage tilt forward / backward ( $\alpha / \beta$ )	degrees 6 / 6
4.2	Lowered mast height	h1 mm 2,675
4.3	Free lift	h2 mm 145
4.4	Lift height	h3 mm 3,040
4.5	Extended mast height	h4 mm 4,375
4.7	Overhead guard height	h6 mm 2,640
4.8	Seat height / standing height rel. to SIP	h7 mm 1,650
4.12	Coupling height	h10 mm 508
4.19	Overall length	l1 mm 5,316
4.20	Length to face of forks	l2 mm 3,971
4.21	Overall width	b1 mm 2,194
4.22	Fork dimensions	s x e x l mm 70 x 180 x 1200
4.23	Fork carriage ISO 2328, class / type A,B	Class IV
4.24	Fork carriage width	b2 mm 2,268
4.31	Ground clearance, loaded, under mast	m1 mm 250
4.32	Ground clearance, centre of wheelbase	m2 mm 302
4.33	Aisle width for pallets 1000 x 1200 crossways (L x W)	Ast mm 5,590
4.34	Aisle width for pallets 800 x 1200 lengthways (W x L)	Ast mm 5,790
4.35	Turning radius	Wa mm 3,700
4.36	Smallest pivot point distance	b13 mm 1,354
Performance Data		
5.1	Travel speed, unloaded	km/h 35
5.2	Lift speed, loaded / unloaded	mm/s 410 / 480
5.3	Lowering speed, loaded / unloaded	mm/s 500 / 500
5.5	Max. Drawbar pull, loaded	N 70,010
5.7	Gradient performance, loaded	% 35.2
5.10	Service brake	FOOT (Hydraulic)
Engine		
6.1	Engine manufacturer / type	CUMMINS / QSF3.8
6.2	Engine power acc. to ISO 1585	kW / rpm 75 kW (102 ps) / 2200
6.3	Maximum torque	kgf-m/rpm 42.3 / 1600
6.4	No. of cylinder / displacement	/cc 4 / 3800
6.5	Fuel consumption acc. to VDI cycle	ℓ/h 8.5
Other Details		
8.1	Type of drive control	Full Auto
8.2	Operating pressure (system/attachments)	kg/cm <sup>2</sup> 210 / 150
8.3	Oil volume for attachments (hydraulic)	ℓ 115
8.4	Sound level at driver's ear according to DIN 12053	db (A) 78.6
8.5	Trailer coupling, type DIN	Pin

LOADS 2B

HYUNDAI

APC

80D-9







- \* Standard and optional equipment may vary per country. Contact your Hyundai dealer for more information.
- \* The photos may include attachments and optional equipment that are not available in your area.
- \* Materials and specifications are subject to change without advance notice.
- \* All imperial measurements rounded off to the nearest pound or inch.



PLEASE CONTACT



30 Burkitt Road  
Earlstrees Industrial Estate  
Corby  
Northants  
NN17 4DT

TEL: **01536 201755**  
Email: [info@ndltcorby.co.uk](mailto:info@ndltcorby.co.uk)